

Product Datasheet

12-port Gigabit Industrial PoE Switch

(ONV-IPS3128PF)



OVERVIEW

The ONV-IPS3128PF is a gigabit industrial PoE fiber switch independently developed by ONV. It has 10*10/100/1000Base-T adaptive RJ45 ports and 2*1000Base-X uplink SFP fiber ports. Port 1-8 can support IEEE 802.3 af/at PoE standard and single-port PoE power up to 30W. As a PoE power supply device, it can automatically detect and recognize the power-receiving equipment that meets the standard and supply power through the network cable. It can supply power to PoE terminal devices such as wireless AP, IP cameras, and industrial sensors through the network cable, and meet the network environment that needs a high-density PoE power supply. It is suitable for intelligent transportation, rail transit, power industry, mining, petroleum, and sea transportation. Industrial scenes such as metallurgy and green energy, construction form a cost-effective, stable, and reliable communication network. Unmanaged model, plug and play, no configuration, easy to use.

FEATURE

■ Gigabit access, uplink SFP fiber port

- ◇ Support non-blocking wire-speed forwarding.
- ◇ Support full-duplex based on IEEE 802.3x and half-duplex based on Backpressure.
- ◇ Support Gigabit RJ45 port and SFP port combination, which enables users to flexibly build networking to meet the needs of various scenarios.

■ Smart PoE power supply

- ◇ Comply with IEEE 802.3 af/at PoE standard, automatically identify PoE devices for power supply, and not damage non-PoE devices.
- ◇ 8*10/100/1000Base-T RJ45 ports can support PoE power supply to meet the needs of PoE power supply in various scenarios in the industrial field.

■ Stable and reliable

- ◇ CCC, CE, FCC, RoHS.
- ◇ The user-friendly panel can show the device status through the LED indicator of PWR, Link, and PoE.
- ◇ Low power consumption, no fan, aluminum shell, and excellent heat dissipation to ensure the stable operation of the switch.

TECHNICAL SPECIFICATION

Model	ONV-IPS3128PF
Interface Characteristics	
Fixed Port	2*1000Base-X uplink SFP fiber ports (Data) 2*10/100/1000Base-T uplink RJ45 ports (Data) 8*10/100/1000Base-T PoE ports (Data/ Power) 2 sets V+, V- redundant DC power port (5P Phoenix terminal)
Ethernet Port	Port 1-10 support 10/100/1000Base-T(X) auto-sensing, full/ half duplex MDI/ MDI-X self-adaption

Twisted Pair Transmission	10BASE-T: Cat3,4,5 UTP (≤100 meters) 100BASE-TX: Cat5 or later UTP (≤100 meters) 1000BASE-T: Cat5e or later UTP (≤100 meters)
Optical Fiber Port	Gigabit optical fiber port, default no include optical module (optional single-mode / multi-mode, single fiber / dual fiber optical module. LC)
Optical Cable/ Distance	Multi-mode: 850nm/ 0-550m, Single-mode: 1310nm/ 0-40km, 1550nm/ 0-120km.
Chip Parameter	
Network Protocol	IEEE 802.3 10BASE-T, IEEE 802.3i 10Base-T, IEEE 802.3u 100Base-TX, IEEE 802.3ab 1000Base-T, IEEE 802.3z 1000Base-X, IEEE 802.3x
Forwarding Mode	Store and Forward (Full Wire Speed)
Switching Capacity	24Gbps (non-blocking)
Forwarding Rate @64byte	17.86Mpps
MAC	8K
Buffer Memory	4M
Jumbo Frames	9.2K
LED Indicator	Power: PWR (Green), Network: Link (Yellow), PoE: PoE (Green), Fiber Port: L/A (Green)
PoE & Power Supply	
PoE Port	Port 1-8
Power Supply Pin	1/2 (+) 3/6 (-)
Max Power Per Port	30W, IEEE 802.3 af/at
Power Consumption	Standby<8W, Full load af<120W, at<240W
Working Voltage	DC44-56V, 5P industrial phoenix terminal, anti-reverse protection.
Power Supply	No, optional 48V/120W or 48V/240W industrial power supply
Physical Parameter	
Operation TEMP/ Humidity	-40~+75°C, 5%~90% RH Non condensing

Storage TEMP/ Humidity	-40~+85°C, 5%~95% RH Non condensing
Dimension	155*135*44mm
Net /Gross Weight	0.6kg / 0.8kg
Installation	Desktop, 35mm DIN Rail
Certification & Warranty	
Lightning Protection	<p>Protection level: IP30</p> <p>Lightning protection: 6KV 8/20us</p> <p>IEC61000-4-3 (RS):10V/m (80~1000MHz)</p> <p>FCC Part 15/CISPR22 (EN55022): Class B</p> <p>IEC61000-6-2 (Common Industrial Standard)</p> <p>IEC61000-4-9 (Pulsed magnet field): 1000A/m</p> <p>IEC61000-4-10 (Damped oscillation): 30A/m 1MHz</p> <p>IEC61000-4-12/18 (Shockwave): CM2.5kV, DM1kV</p> <p>IEC61000-4-4(EFT): Power cable: ±4kV, data cable: ±2kV</p> <p>IEC61000-4-16 (Common-mode transmission): 30V, 300V, 1s</p> <p>IEC61000-4-2 (ESD): ±8kV contact discharge, ±15kV air discharge</p> <p>IEC61000-4-6 (Radio frequency transmission): 10V(150kHz~80MHz)</p> <p>IEC61000-4-8 (Power frequency magnetic field): 100A/m, 1000A/m, 1s-3s</p> <p>IEC61000-4-5 (Surge): Power cable: CM±4kV/ DM±2kV, data cable: ±4kV</p>
Mechanical Properties	IEC60068-2-6 (Anti Vibration), IEC60068-2-32 (Free Fall), IEC60068-2-27 (Anti Shock)
Certification	CCC, CE mark, commercial, CE/LVD EN62368-1, FCC Part 15 Class B, RoHS
Warranty	5 years, lifelong maintenance.

DIMENSION

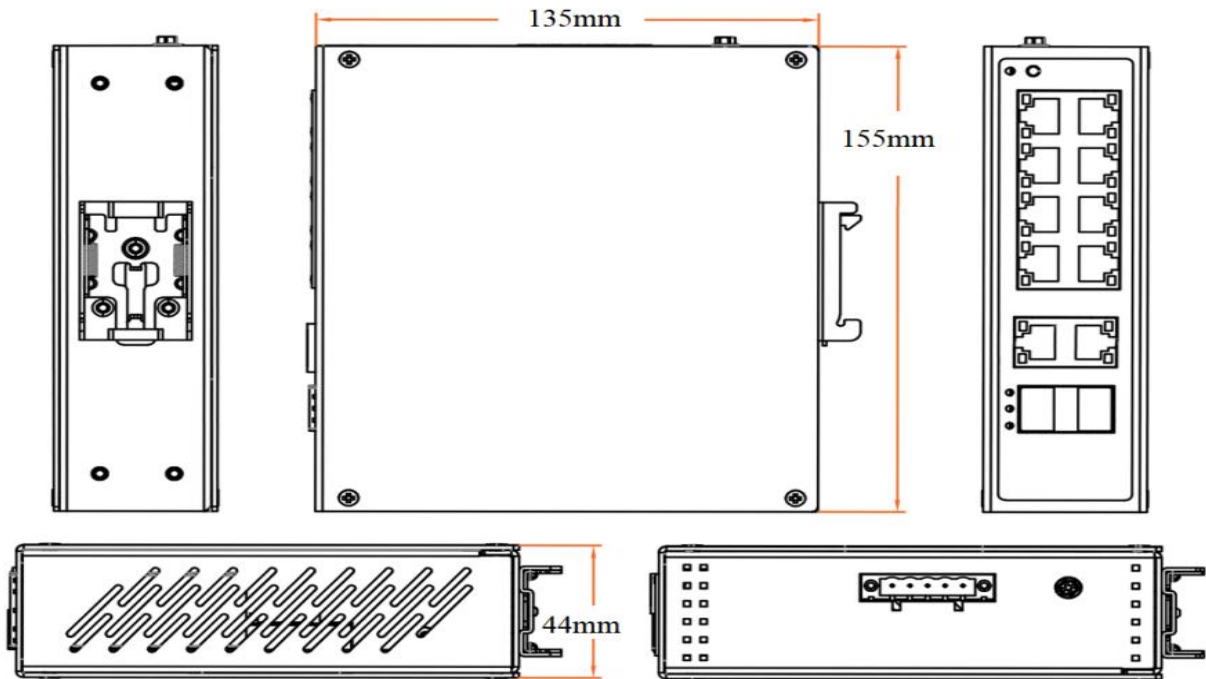

APPLICATION

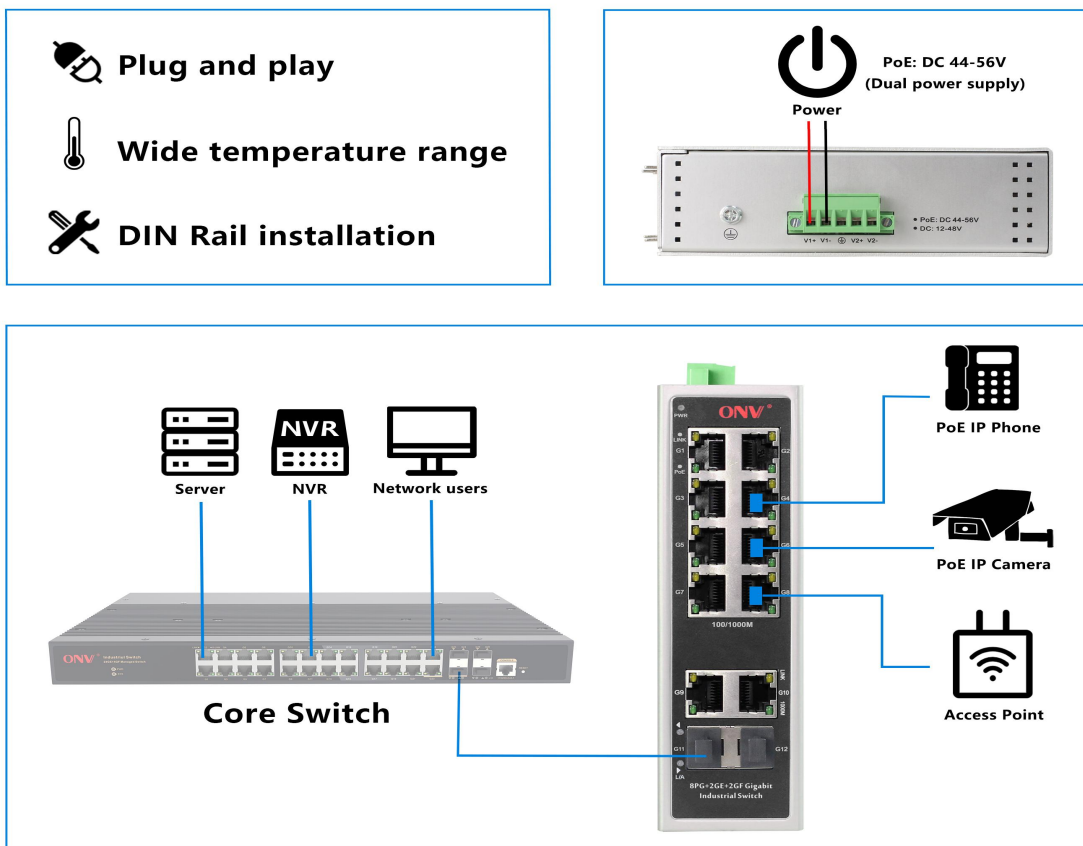

ORDERING INFORMATION

Model	Description	Recommended power supply
ONV-IPS3128PF	Unmanaged industrial PoE switch with 10*10/100/1000M RJ45 ports and 2*1000M uplink SFP fiber ports. Port 1-8 can support IEEE 802.3 af/at PoE standard. It can support dual DC power input and DIN rail mounting.	120W/240W
Note: The optical module and power supply are not included and need to be purchased.		

PACKING LIST

Packing List	Content	Qty	Unit
	12-port gigabit industrial PoE switch	1	SET
	User Guide	1	PC
	Warranty Card and Certificate of Conformity	1	PC

OPTICAL MODULE

Product	Model	Description	Unit
1.25G Optical Module	2630-G	Industrial SFP optical module, 1.25G multi-mode dual fiber 850nm, transmission distance: 550m, LC interface. supports DDM function and hot plugging.	PC
	2632-G	Industrial SFP optical module, 1.25G single-mode dual fiber 1310nm, transmission distance: 20km, LC interface. supports DDM function and hot plugging.	PC
	2612-T-G	Industrial SFP optical module, 1.25G single-mode single fiber TX1310nm/ RX1550nm, transmission distance: 20km, LC interface. supports DDM function and hot plugging.	PC

	2613-R-G	Industrial SFP optical module, 1.25G single-mode single fiber TX1550nm/ RX1310nm, transmission distance: 20km, LC interface. supports DDM function and hot plugging.	PC
	2612-T-SC-G	Industrial SFP optical module, 1.25G single-mode single fiber TX1310nm/ RX1550nm, transmission distance: 20km, SC interface. supports DDM function and hot plugging.	PC
	2613-R-SC-G	Industrial SFP optical module, 1.25G single-mode single fiber TX1550nm/ RX1310nm, transmission distance: 20km, SC interface. supports DDM function and hot plugging.	PC

POWER SUPPLY

Product	Model	Description	Unit
130W Desktop Power Adapter	GWS-AP130-52	Desktop 130W single set of output power adapter Input Voltage: AC100V~240V 50-60Hz, 2.3A Output Voltage: DC52V, 2.5A Operation Temperature: -20°C to +65°C	PC
250W Desktop Power Adapter	GWS-AP250-52	Desktop 250W single set of output power adapter Input Voltage: AC100V~240V 50-60Hz, 5.0A Output Voltage: DC52V, 5.0A Operation Temperature: -20°C to +65°C	PC
120W DIN Rail Industrial Power Supply	GWS-DP120-48	DIN Rail 120W single set of output power supply Input Voltage: AC100V~240V 50-60Hz, 2.3A Output Voltage: DC48V, 2.5A Operation Temperature: -40°C to +70°C	PC
240W DIN Rail Industrial Power Supply	GWS-DP240-48	DIN Rail 240W single set of output power supply Input Voltage: AC100V~240V 50-60Hz, 3.0A Output Voltage: DC48V, 5.0A Operation Temperature: -40°C to +70°C	PC

CONTACT US

ONV Optical Network Video Technologies (Shenzhen) Co., Ltd.

Tel: 0086-755-33376606

Fax: 0086-755-33376608

Email: onv@onv.com.cn

Skype: onv@onv.com.cn

WeChat ID: ONV-PoE-IoT

Website: www.onvcom.com

Headquarter Address: Room 1003, Block D, Terra Building, Futian District, Shenzhen

Factory Address: Building B3, Galaxy Artificial Intelligence Industrial Park, No. 333, Zhongkai 6th Road, Chenjiang Street, Zhongkai High-tech Zone, Huizhou

