

## Product Datasheet

# 1.25G 1310/1550nm&1550/1310nm 20km Optical Transceiver

(2612-T-G&2613-R-G)



## Description

2612-T-G&2613-R-G SFP-BIDI transceivers are high performance, cost effective modules supporting dual data-rate of 1.25Gbps/1.0625Gbps and 20km transmission distance with SMF. The transceiver consists of three sections: a FP/DFB laser transmitter, a PIN photodiode integrated with a trans-impedance preamplifier (TIA) and MCU control unit. All modules satisfy class I laser safety requirements. The transceivers are compatible with SFP Multi-Source Agreement (MSA) and SFF-8472. For further information, please refer to SFP MSA.

## Feature

Bi-Directional LC connector

Hot pluggable SFP footprint

Low power consumption <0.8W

Operating temperature: -40~+85°C

Digital Diagnostic Monitor Interface

Applicable for 20Km SMF connection

Support 1.25Gbps/1.0625Gbps bit rates

Compliant with SFP MSA and SFF-8472

Very low EMI and excellent ESD protection

**2612-T-G:** 1310nm FP laser and 1550nm PIN photo detector

**2613-R-G:** 1550nm DFB laser and 1310nm PIN photo detector

## Application

Fiber Channel

Gigabit Ethernet

Other Optical Links

Router/ Server interface

Switch to Switch interface

Switched backplane applications

## Functional Diagram

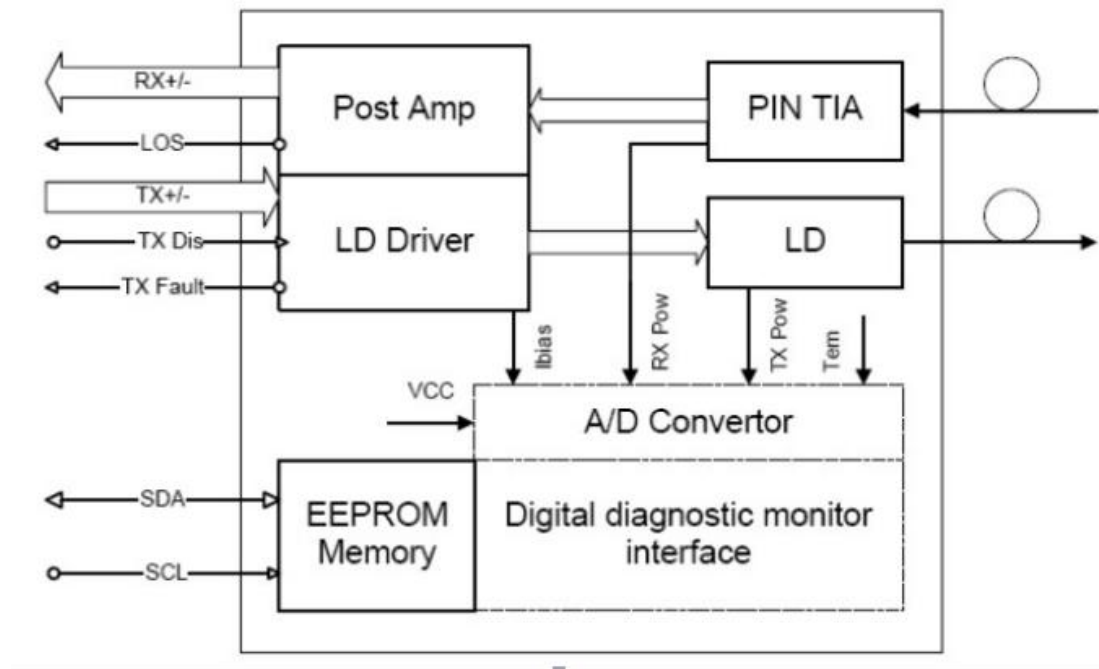

## Absolute Max Ratings

Parameter	Symbol	Min.	Max.	Unit
Supply Voltage	Vcc	-0.5	4.0	V
Storage Temperature	TS	-40	85	°C
Relative Humidity	RH	0	85	%

**Note:** Stress in excess of the maximum absolute ratings can cause permanent damage to the transceiver.

## General Operating Characteristics

Parameter	Symbol	Min.	Typ	Max.	Unit
Data Rate	DR	1.0625	1.25		Gb/s
Supply Voltage	Vcc	3.13	3.3	3.47	V
Supply Current	Icc5			220	mA
Operating Case Temp.	Tc	0		70	°C

## Electrical Characteristics

Parameter	Symbol	Min.	Typ	Max.	Unit	Note
<b>Transmitter</b>						
Differential data input swing	VIN,PP	120		820	mVpp	1
Tx Disable Input-High	VIH	2.0		Vcc+0.3	V	
Tx Disable Input-Low	VIL	0		0.8	V	
Tx Fault Output-High	VOH	2.0		Vcc+0.3	V	2
Tx Fault Output-Low	VOL	0		0.8	V	2
Input differential impedance	Rin		100		Ω	
<b>Receiver</b>						
Differential data output swing	Vout,pp	340	650	800	mVpp	3
Rx LOS Output-High	VROH	2.0		Vcc+0.3	V	2
Rx LOS Output-Low	VROL	0		0.8	V	2

### Notes:

1. TD+/- are internally AC coupled with 100Ω differential termination inside the module.
2. Tx Fault and Rx LOS are open collector outputs, which should be pulled up with 4.7k to 10kΩ resistors on the host board. Pull up voltage between 2.0V and Vcc+0.3V.

3. RD+/- outputs are internally AC coupled, and should be terminated with 100Ω (differential) at the user SERDES.

## Optical Characteristics

Parameter	Symbol	Min.	Typ	Max.	Unit	Note
<b>Transmitter</b>						
Operating Wavelength	$\lambda$	1270	1310	1360	nm	2612-T-G
		1510	1550	1570		2613-R-G
Ave. output power (Enabled)	PAVE	-9		-3	dBm	1
Extinction Ratio	ER	9			dB	1
Side-Mode Suppression Ratio	SMSR	30			dB	
RMS spectral width 1310nm FP	$\Delta\lambda$			3	nm	
RMS spectral width 1550nm DFB				1	nm	
Rise/Fall time (20%~80%)	Tr/Tf			0.26	ns	2
Dispersion penalty	TDP			3.9	dB	
Output Optical Eye	Compliant with IEEE802.3 z (class 1 aser safety)					
<b>Receiver</b>						
Operating Wavelength	$\lambda$	1510	1550	1570	nm	2612-T-G
		1270	1310	1360		2613-R-G
Receiver Sensitivity	PSEN1			-22	dBm	3
Overload	PAVE	-3			dBm	3
LOS Assert	Pa	-35			dBm	
LOS De-assert	Pd			-24	dBm	
LOS Hysteresis	Pd-Pa	0.5			dB	

### Notes:

1. Measured at 1250Mb/s with PRBS 2 223–1NRZ test pattern.
2. Unfiltered, measured with a PRBS223–1 test pattern @1.25Gbps.
3. Measured at 1250Mb/s with PRBS 223–1 NRZ test pattern for BER<1x10-12.

## Pin Defintion And Functions

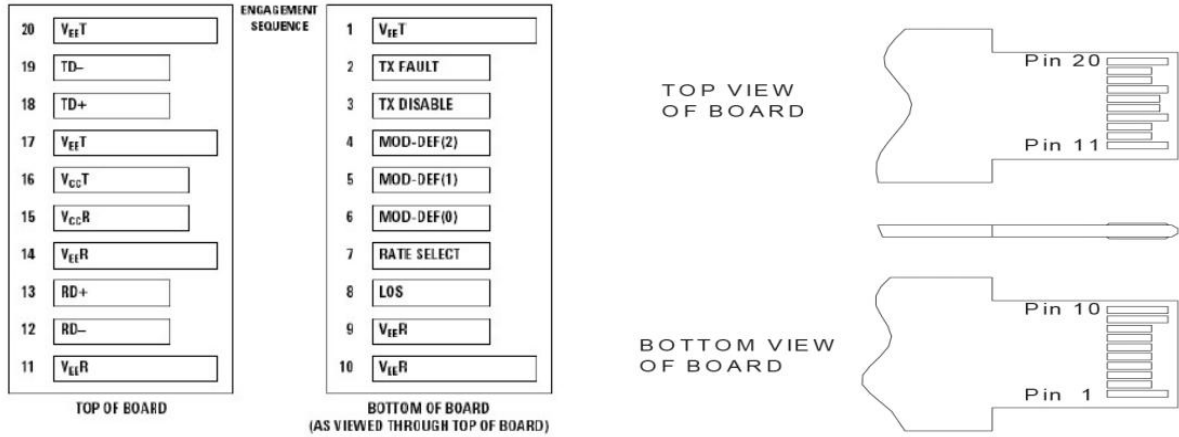

Pin	Symbol	Name/Description	Notes
1	VeeT	Tx ground	
2	Tx Fault	Tx fault indication, Open Collector Output, active “H”	1
3	Tx Disable	LVTTL Input, internal pull-up, Tx disabled on “H”	2
4	MOD-DEF2	2 wire serial interface data input/output (SDA)	3
5	MOD-DEF1	2 wire serial interface clock input (SCL)	3
6	MOD-DEF0	Model present indication	3
7	Rate select	No connection	
8	LOS	Rx loss of signal, Open Collector Output, active “H”	4
9	VeeR	Rx ground	
10	VeeR	Rx ground	
11	VeeR	Rx ground	
12	RD-	Inverse received data out	5
13	RD+	Received data out	5
14	VeeR	Rx ground	
15	VccR	Rx power supply	
16	VccT	Tx power supply	
17	VeeT	Tx ground	
18	TD+	Transmit data in	6
19	TD-	Inverse transmit data in	6
20	VeeT	Tx ground	

**Notes:**

1. When high, this output indicates a laser fault of some kind. Low indicates normal operation. And should be pulled up with a 4.7–10KΩ resistor on the host board.

2. TX disable is an input that is used to shut down the transmitter optical output. It is pulled up within the module with a 4.7–10KΩ resistor. Its states are:

Low (0–0.8V): Transmitter on ( $>0.8, < 2.0V$ ): Undefined

High (2.0V~V<sub>cc</sub>+0.3V): Transmitter Disabled Open: Transmitter Disabled

3. Mod-Def 0,1,2. These are the module definition pins. They should be pulled up with a 4.7K–10KΩ resistor on the host board. The pull-up voltage shall be between 2.0V~V<sub>cc</sub>+0.3V.

Mod-Def 0 has been grounded by the module to indicate that the module is present

Mod-Def 1 is the clock line of two wire serial interface for serial ID

Mod-Def 2 is the data line of two wire serial interface for serial ID

4. When high, this output indicates loss of signal (LOS). Low indicates normal operation.

5. **RD+/-**: These are the differential receiver outputs. They are AC coupled 100Ω differential lines which should be terminated with 100Ω (differential) at the user SERDES. The AC coupling is done inside the module and is thus not required on the host board.

6. **TD+/-**: These are the differential transmitter inputs. They are AC-coupled, differential lines with 100Ω differential termination inside the module. The AC coupling is done inside the module and is thus not required on the host board.

## Digital Diagnostic Specifications

The transceivers can be used in host systems that require either internally or externally calibrated digital diagnostics.

Parameter	Symbol	Units	Min.	Max.	Accuracy	Note
Transceiver temperature	DTemp-E	°C	-5	+75	±5°C	
Transceiver supply voltage	DVoltage	V	2.8	4.0	±3%	
Transmitter bias current	DBias	mA	2	80	±10%	1
Transmitter output power	DTx-Power	dBm	-12	0	±3dB	
Receiver average input power	DRx-Power	dBm	-25	0	±3dB	

### Notes:

1. The accuracy of the Tx bias current is 10% of the actual current from the laser driver to the laser
2. Internal/ External Calibration compatible.

## Typical Interface Circuit

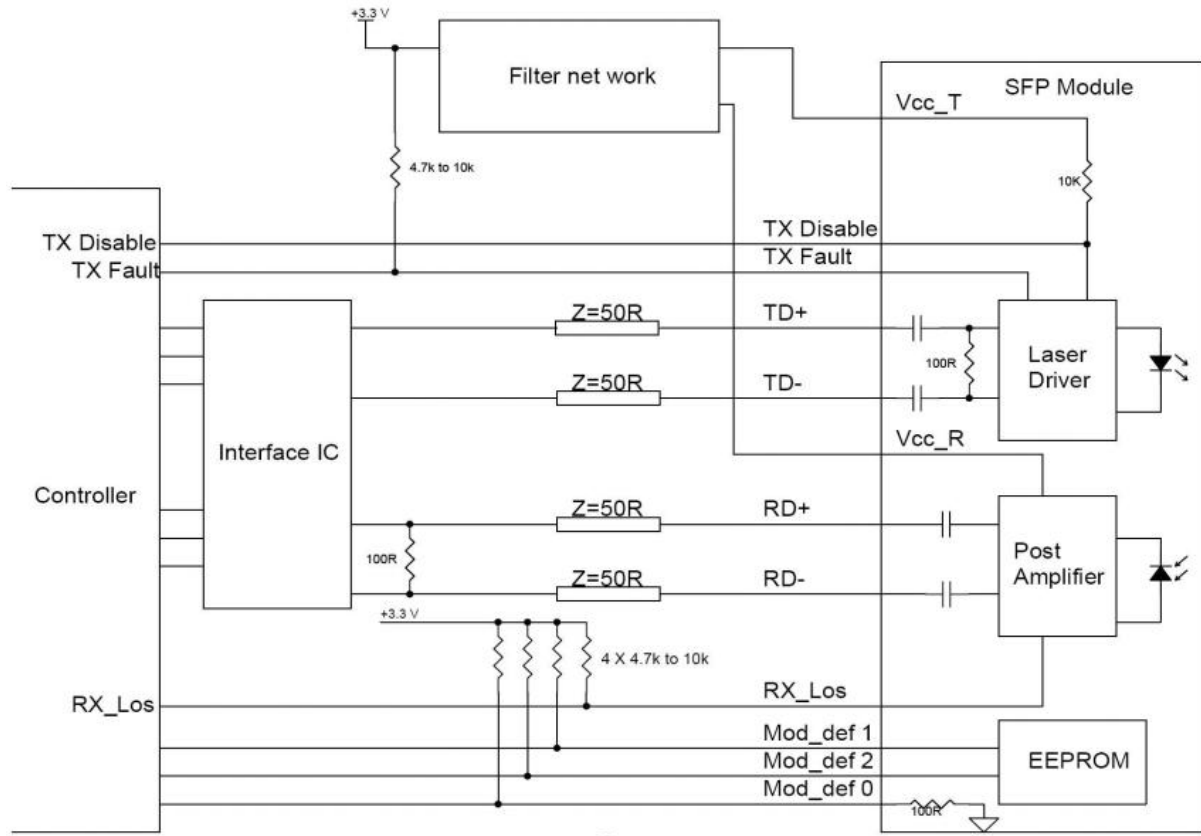

## Package Dimensions

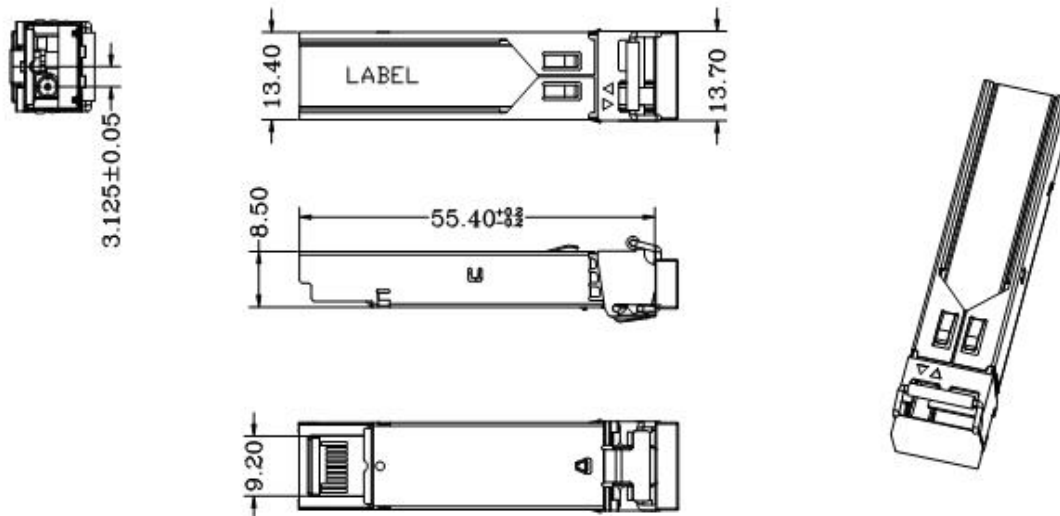

Units in mm  
Tolerance without indication is  $\pm 0.1$ mm

Wavelength	Latch Color
TX 1310nm	Blue
TX 1550nm	Yellow

## Ordering Information

Part Number	Description
2612-T-G	SFP BIDI, 1.25G ,1310/1550nm, 20Km, -40~+85°C, with DDM
2613-R-G	SFP BIDI, 1.25G ,1550/1310nm, 20Km, -40~+85°C, with DDM